



## LEISTUNGSERKLÄRUNG



DoP: 0050

für fischer Schwerlastanker TA M, TA M S, TA M T (Metалldübel zur Verwendung im Beton (hoch belastbar)) – DE

1. Eindeutiger Kenncode des Produkttyps: **DoP: 0050**
2. Verwendungszweck(e): **Nachträgliche Befestigung im ungerissenen Beton, siehe Anhang, insbesondere Anhänge B 1 bis B 3**
3. Hersteller: **fischerwerke GmbH & Co. KG, Klaus-Fischer-Straße 1, 72178 Waldachtal, Deutschland**
4. Bevollmächtigter: --
5. System(e) zur Bewertung und Überprüfung der Leistungsbeständigkeit: **1**
6. Europäisches Bewertungsdokument: **EAD 330232-00-0601**

Europäische Technische Bewertung: **ETA-04/0003; 2018-06-12**

Technische Bewertungsstelle: **DIBt**

Notifizierte Stelle(n): **1343 – MPA Darmstadt**

7. Erklärte Leistung(en):

### **Mechanische Festigkeit und Standsicherheit (BWR 1)**

- **Charakteristische Zugtragfähigkeit (statische und quasi-statische Einwirkungen):  
Siehe Anhang, insbesondere Anhang C 1**
- **Charakteristische Quertragfähigkeit (statische und quasi-statische Einwirkungen):  
Siehe Anhang, insbesondere Anhang C 2**
- **Verschiebungen (statische und quasi-statische Einwirkungen): Siehe Anhang, insbesondere Anhang C 2**
- **Charakteristischer Widerstand und Verschiebungen für seismische Leistungskategorien C1 und C2: KLF**

### **Brandschutz (BWR 2)**

- **Brandverhalten: Der Dübel erfüllt die Anforderungen der Klasse A 1**
- **Feuerwiderstand: KLF**

8. Angemessene Technische Dokumentation und/oder Spezifische Technische Dokumentation: ---

Die Leistung des vorstehenden Produkts entspricht der erklärten Leistung/den erklärten Leistungen. Für die Erstellung der Leistungserklärung im Einklang mit der Verordnung (EU) Nr. 305/2011 ist allein der obengenannte Hersteller verantwortlich.

Unterszeichnet für den Hersteller und im Namen des Herstellers von:

Andreas Bucher, Dipl.-Ing.

Wolfgang Hengesbach, Dipl.-Ing., Dipl.-Wirtsch.-Ing.

*i.V. A. Bucher*

*i.V. W. Hengesbach*

Tumlingen, 2018-06-19

- Diese Leistungserklärung wurde in verschiedenen Sprachversionen erstellt. Für den Fall unterschiedlicher Auslegung hat immer die englische Version Vorrang.
- Der Anhang enthält freiwillige und ergänzende Informationen in englischer Sprache. Diese gehen über die (sprachneutral angegebenen) gesetzlichen Anforderungen hinaus.

**Specific Part**

**1 Technical description of the product**

The Fischer Heavy-duty anchor TA M, TA M S and TA M T in the range of M6, M8, M10 and M12 is an anchor made of galvanised steel which is placed into a drilled hole and anchored by torque-controlled expansion with the hexagon head bolt.

The product description is given in Annex A.

**2 Specification of the intended use in accordance with the applicable European Assessment Document**

The performances given in Section 3 are only valid if the concrete screw is used in compliance with the specifications and conditions given in Annex B.

The verifications and assessment methods on which this European Technical Assessment is based lead the assumption of working life of the concrete screw of at least 50 years. The indications given on the working life cannot be interpreted as a guarantee given by the producer, but are to be regarded only as a means for choosing the right products in relation to the expected economically reasonable working life of the works.

**3 Performance of the product and references to the methods used for its assessment**

**3.1 Mechanical resistance and stability (BWR 1)**

Essential characteristic	Performance
Characteristic resistance to tension load (static and quasi-static loading)	see Annex C 1
Characteristic resistance to shear load (static and quasi-static loading)	see Annex C 2
Displacements (static and quasi-static loading)	see Annex C 2
Characteristic resistance and displacements for seismic performance categories C1 and C2	No performance assessed

**3.2 Safety in case of fire (BWR 2)**

Essential characteristic	Performance
Reaction to fire	Class A1
Resistance to fire	No performance assessed

**4 Assessment and verification of constancy of performance (AVCP) system applied, with reference to its legal base**

In accordance with European Assessment Documents EAD No. 330232-00-0601 the applicable European legal act is: [96/582/EC].

The system to be applied is: 1

**Pre-positioned installation:**

**TA M**

The hexagon head screw and the washer according to table A4.1 and A4.2 must be provided by the user

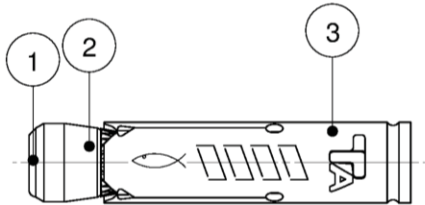

**TA M S**

The hexagon head screw is provided by the manufacturer (fischer) together with the anchor

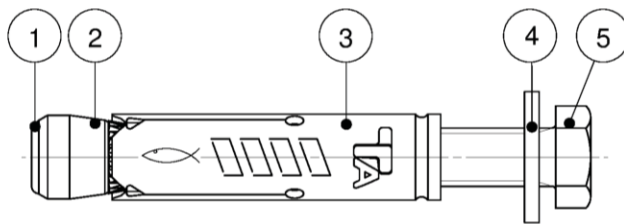

**In-place installation:**

**TA M T**

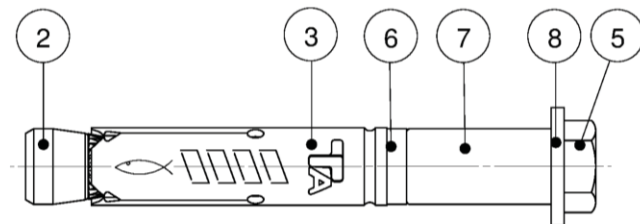

- |                          |                      |
|--------------------------|----------------------|
| ① Plastic cap (optional) | ⑤ Hexagon head screw |
| ② Cone-nut               | ⑥ Distance ring      |
| ③ Expansion sleeve       | ⑦ Spacing sleeve     |
| ④ Washer (TA M / TA M S) | ⑧ Washer (TA M T)    |

(Fig. not to scale)

**fischer Heavy-duty anchor TA M, TA M S, TA M T**

**Product description**  
Anchor types

**Annex A 1**

**TAM / TAM S**

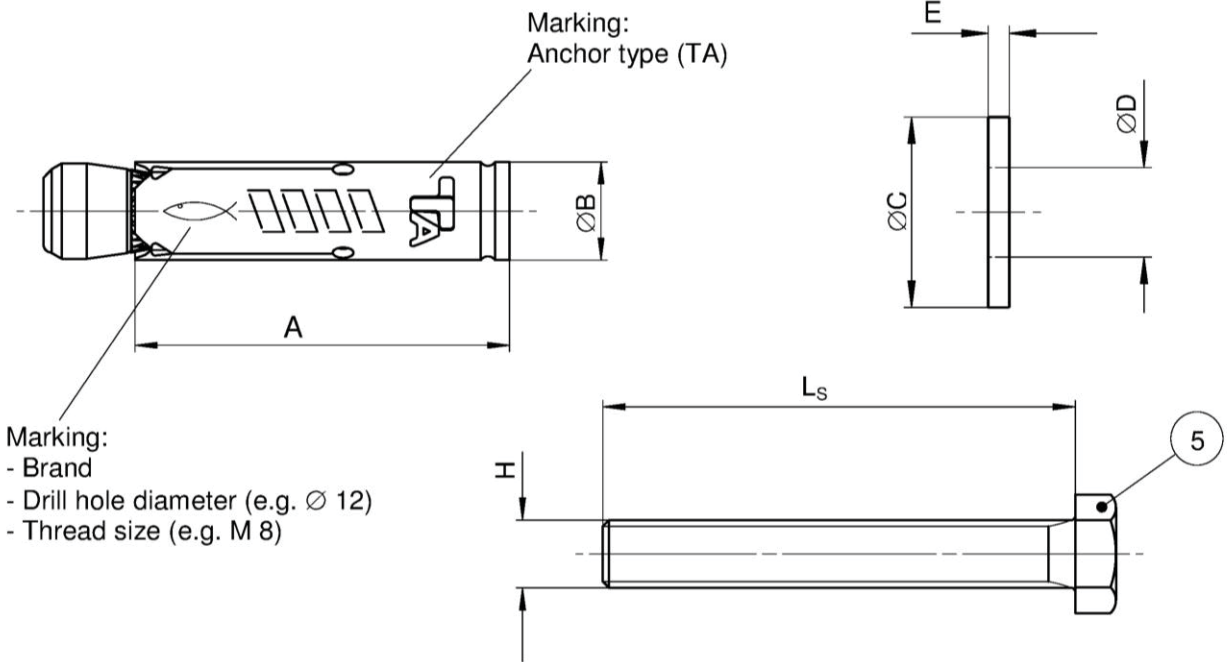

**TAM T**

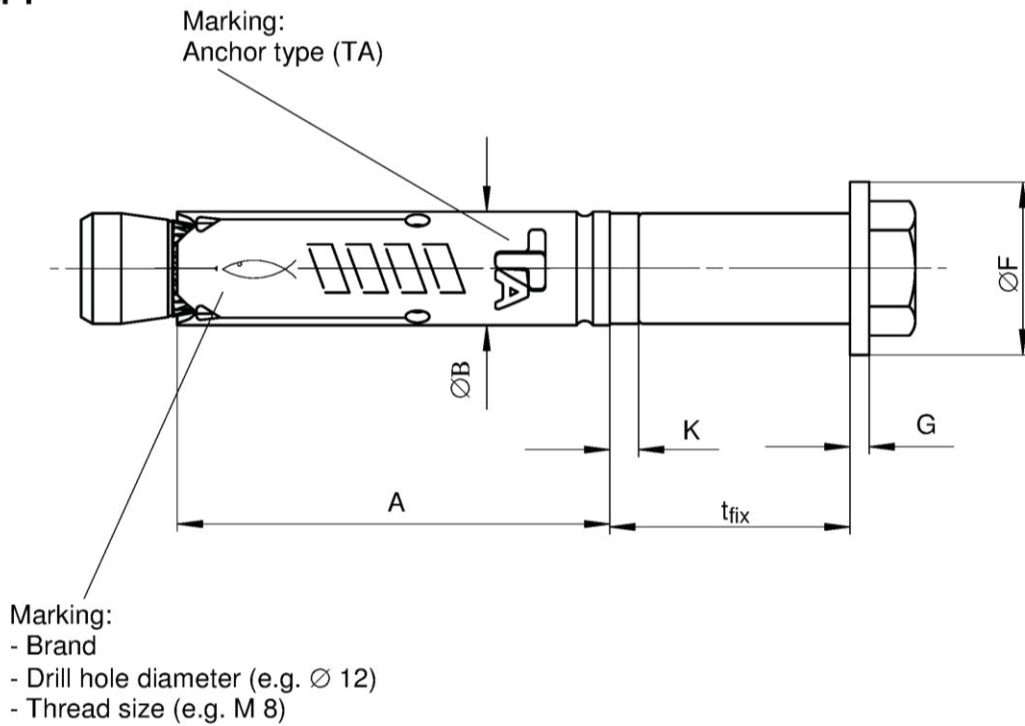

(Fig. not to scale)

**fischer Heavy-duty anchor TAM, TAM S, TAM T**

**Product description**  
Anchor components

**Annex A 2**

**Table A3.1: Anchor dimensions [mm]**

Part	Designation	Type of anchor		M6	M8	M10	M12
3	Expansion sleeve	TA M / TA M S / TA M T	A	40,0	45,0	55,0	70,0
			∅ B	9,6	11,8	14,5	17,5
4	Washer <sup>1)</sup>	TA M S	∅ C ≥	11,0	15,0	19,0	23,0
			E ≥	1,4	1,4	1,8	2,3
8	Washer	TA M T	∅ F ≥	17,0	21,0	25,0	30,0
			G ≥	1,4	1,8	2,3	2,7
5	Hexagon head screw <sup>2)</sup>	TA M S / TA M T	L <sub>s</sub> ≥	t <sub>fix</sub> + 50	t <sub>fix</sub> + 55	t <sub>fix</sub> + 70	t <sub>fix</sub> + 85
			H	M6	M8	M10	M12
6	Distance ring	TA M T	K =	3,0	3,0	3,0	3,0

<sup>1)</sup> For specification - summary of washer for TA M see table A4.2

<sup>2)</sup> For specification - summary of hexagon head screw for TA M see table A4.1

**Table A3.2: Materials**

Part	Designation	Type of anchor	Materials	Treatment
1	Plastic cap <sup>1)</sup>	TA M / TA M S	Polyamide	-
2	Cone-nut	TA M / TA M S / TA M T	Steel, EN 10277:2008	Zinc plated according to EN ISO 4042:2017, min 5 µm, additional functional coating
3	Expansion sleeve	TA M / TA M S / TA M T	Cold-rolled steel EN 10139:2016	Zinc plated according to EN ISO 4042:2017, min 5 µm
4	Washer <sup>2)</sup>	TA M S	Steel, min 140 HV	
8	Washer	TA M T		
5	Hexagon head screw <sup>3)</sup>	TA M S / TA M T	Steel, property class 8.8	
6	Distance ring	TA M T	Polyethylen	-
7	Distance sleeve	TA M T	Cold-rolled steel EN 10139:2016/ Steel EN 10 277:2008	Zinc plated according to EN ISO 4042:2017, min 5 µm

<sup>1)</sup> Optional

<sup>2)</sup> For specification - summary of washer for TA M see table A4.2

<sup>3)</sup> For specification - summary of hexagon head screw for TA M see table A4.1

**fischer Heavy-duty anchor TA M, TA M S, TA M T**

**Product description**  
Anchor dimensions  
Materials

**Annex A 3**

**Table A4.1:** Selection criteria for the hexagon head screw (TA M)

Description			TA M6	TA M8	TA M10	TA M12
Length of hexagon head screw	$L_s$	[mm]	$\geq t_{fix} + 50$	$\geq t_{fix} + 55$	$\geq t_{fix} + 70$	$\geq t_{fix} + 85$
Thread size	H	[-]	M6	M8	M10	M12
Standardisation			ISO 4014:2017 / ISO 4017:2014 or DIN 931:1987 / DIN 933:1987			
Material			Steel, property class 8.8			
Treatment			Zinc plated according to EN ISO 4042:2017, min 5 $\mu$ m			

**Table A4.2:** Selection criteria for the washer (TA M)

Description			TA M6	TA M8	TA M10	TA M12
Hole diameter	D	min	6,0	8,0	10,0	12,0
		max	6,6	8,6	10,8	13,3
External diameter	C	[mm]	$\geq 11,0$	$\geq 15,0$	$\geq 19,0$	$\geq 23,0$
Thickness	E	min	1,4	1,4	1,8	2,3
		max	3,0	3,0	4,0	5,0
Material			Steel, hardness class min 140 HV			
Treatment			Zinc plated according to EN ISO 4042:2017, min 5 $\mu$ m			

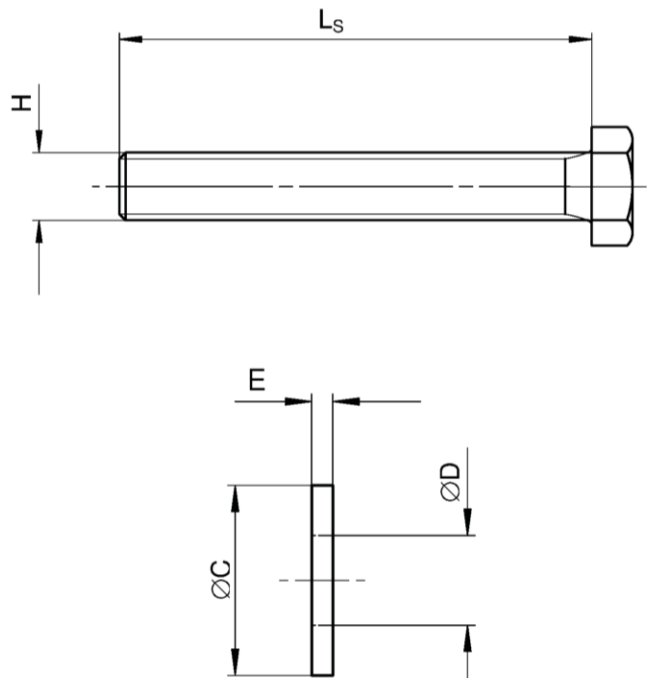

(Fig. not to scale)

**fischer Heavy-duty anchor TA M, TA M S, TA M T**

**Product description**  
Dimensions  
Materials

**Annex A 4**

### Specifications of intended use

fischer Heavy-duty anchor	TA M6	TA M8	TA M10	TA M12
Steel, zinc plated			✓	
Static and quasi-static loads			✓	
Uncracked concrete			✓	

**Base materials:**

- Normal weight concrete according to EN 206-1:2000
- Strength classes C20/25 to C50/60 according to EN 206-1:2000

**Use conditions (Environmental conditions):**

- Structures subject to dry internal conditions

**Design:**

- Anchorages have to be designed under the responsibility of an engineer experienced in anchorages and concrete work
- Verifiable calculation notes and drawings have to be prepared taking account of the loads to be anchored. The position of the anchor is indicated on the design drawings (e.g. position of the anchor relative to reinforcement or to supports, etc.)
- Design of fastenings according to FprEN 1992-4: 2016 and EOTA Technical Report TR 055

**Installation:**

- Anchor installation carried out by appropriately qualified personnel and under the supervision of the person responsible for technical matters of the site
- Hammer or hollow drilling according to Annex B3
- Drill hole created perpendicular  $\pm 5^\circ$  to concrete surface, positioning without damaging the reinforcement
- In case of aborted hole: new drilling at a minimum distance twice the depth of the aborted drill hole or smaller distance if the aborted drill hole is filled with high strength mortar and if under shear or oblique tension load it is not in the direction of load application

**fischer Heavy-duty anchor TA M, TA M S, TA M T**

**Intended use**  
Specifications

**Annex B 1**

**Table B2.1:** Installation parameters for TA M / TA M S / TA M T

Anchor size		TA M6	TA M8	TA M10	TA M12
Nominal drill hole diameter	$d_0$	10	12	15	18
Maximum drill bit diameter	$d_{cut} \leq$	10,45	12,50	15,50	18,50
Length of hexagon head screw	$L_s \geq$	$t_{fix} + 50$	$t_{fix} + 55$	$t_{fix} + 70$	$t_{fix} + 85$
Depth of drill hole (TA M / TA M S)	$h_1 \geq$	$L_s - t_{fix} + 15$		$L_s - t_{fix} + 20$	
Depth of drill hole (TA M T)	$h_1 \geq$	$L_s + 10$			
Diameter of clearance hole in the fixture (TA M / TA M S)	$d_f \leq$	7	9	12	14
Diameter of clearance hole in the fixture (TA M T)	$d_f \leq$	12	14	18	20
Thickness of fixture	$t_{fix, min}$	1			
	$t_{fix, max}$	150	200	250	300
Required torque moment	$T_{inst}$ [Nm]	10	20	40	75

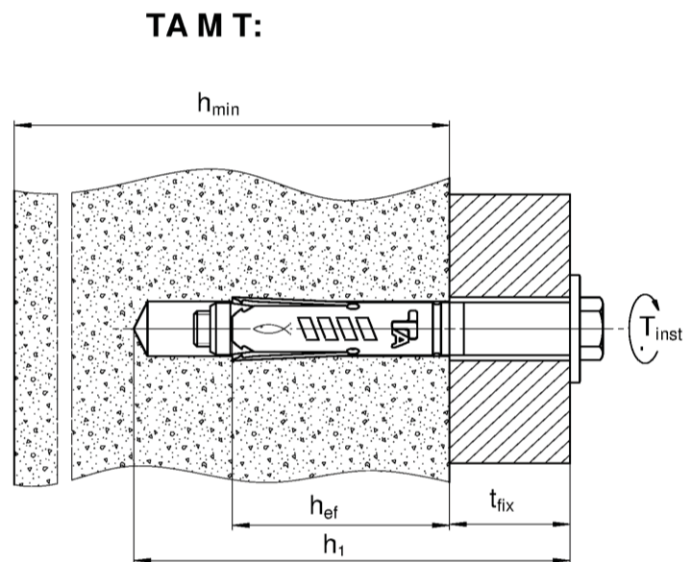
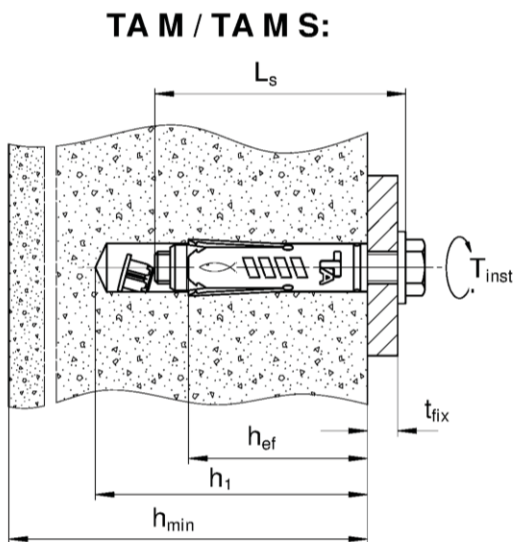

$L_s$  = Length of hexagon head screw  
 $h_{ef}$  = Effective embedment depth  
 $t_{fix}$  = Thickness of the fixture

$h_{min}$  = Minimum thickness of concrete member  
 $h_1$  = Depth of drill hole to deepest point  
 $T_{inst}$  = Required setting torque

**Table B2.2:** Minimum thickness of concrete member, minimum spacing and minimum edge distances

Anchor size		TA M6	TA M8	TA M10	TA M12
Minimum thickness of concrete member	$h_{min}$	100	100	110	140
Minimum spacing	$s_{min}$ [mm]	80	90	110	160
Minimum edge distance	$c_{min}$	50	60	70	120

(Fig. not to scale)

**fischer Heavy-duty anchor TA M, TA M S, TA M T**

**Intended Use**  
 Installation instructions  
 Minimum thickness of concrete member, minimum spacing and minimum edge distance

**Annex B 2**



**Installation instruction**

**Pre-positioned installation TA M / TA M S**

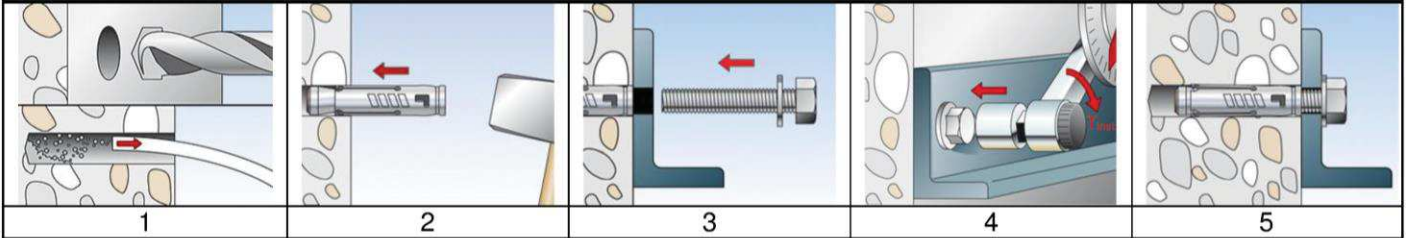

No.	Description	
1	Create drill hole with hammer drill, clean bore hole	Create drill hole with hollow drill and vacuum cleaner
2	Set the fastener	
3	Attach the fixture and turn the screw in	
4	Apply required torque moment $T_{inst}$	
5	Installed fastener	

**Push-through installation TA M T**

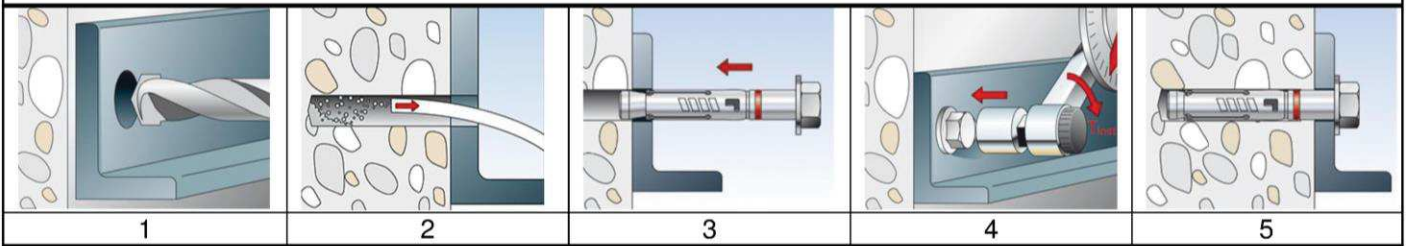

No.	Description	
1	Create drill hole with hammer drill	Create drill hole with hollow drill and vacuum cleaner
2	Clean bore hole	-
3	Set the fastener	
4	Apply required torque moment $T_{inst}$	
5	Installed fastener	

**Types of drills**

Hammer drill



Hollow drill



**fischer Heavy-duty anchor TA M, TA M S, TA M T**

**Intended use**  
Installation instruction

**Annex B 3**

<b>Table C 1.1: Characteristic <i>tension</i> resistance under static and quasi-static loads</b>						
Anchor size			<b>TA M6</b>	<b>TA M8</b>	<b>TA M10</b>	<b>TA M12</b>
<b>Steel failure</b>						
Characteristic resistance property class 8.8	$N_{Rk,s}$	[kN]	16,1	29,3	46,4	67,4
Partial factor	$\gamma_{Ms}$ <sup>1)</sup>	[-]	1,5			
<b>Pull-out failure</b>						
Characteristic resistance in uncracked concrete	$N_{Rk,p}$	[kN] C20/25	7,5	12	20	25
Increasing factors for $N_{Rk,p}$ for uncracked concrete	$\psi_c$	C25/30	1,12			
		C30/37	1,22			
		C35/45	1,32			
		C40/50	1,41			
		C45/55	1,50			
		C50/60	1,58			
Installation factor	$\gamma_{inst}$	[-]	1,0			
<b>Concrete cone failure and splitting failure</b>						
Effective embedment depth	$h_{ef}$	[mm]	40	45	55	70
Factor $k_1$	$k_{ucr,N}$	[-]	11,0 <sup>2)</sup>			
Spacing (concrete cone failure)	$s_{cr,N}$	[mm]	120	135	220	210
Edge distance (concrete cone failure)	$c_{cr,N}$		60	68	110	105
Spacing (splitting)	$s_{cr,sp}$		120	180	330	420
Edge distance (splitting)	$c_{cr,sp}$		60	90	165	210
<sup>1)</sup> In absence of other national regulations <sup>2)</sup> Based on concrete strength as cylinder strength						
<b>fischer Heavy-duty anchor TA M, TA M S, TA M T</b>					<b>Annex C 1</b>	
<b>Performances</b> Characteristic <i>tension</i> resistance under static and quasi-static loads						

<b>Table C2.1:</b> Characteristic values of <b>shear</b> resistance under static and quasi-static loads					
Anchor size		TA M6	TA M8	TA M10	TA M12
<b>Shear load without lever arm</b>					
Characteristic resistance property class 8.8	$V_{Rk,s}^0$ [kN]	5,8	11,7	19,2	29,8
Partial factor	$\gamma_{Ms}^{1)}$ [-]	1,25			
Ductility factor	$k_7$ [-]	1,0			
<b>Shear load with lever arm</b>					
Characteristic bending moment property class 8.8	$M_{Rk,s}^0$ [Nm]	12	30	60	105
Partial factor	$\gamma_{Ms}^{1)}$ [-]	1,25			
<b>Concrete pryout failure</b>					
Ductility factor	$k_7$ [-]	1,0			
Factor	$k_8$ [-]	1,1	1,8	1,8	2,0
<b>Concrete edge failure</b>					
Effective length of the fastener	$l_f$ [mm]	40	45	55	70
Outside diameter of fastener	$d_{nom}$ [mm]	10	12	15	18
1) In absence of other national regulations					
<b>Table C2.2:</b> Displacements under static and quasi static <b>tension</b> loads					
Anchor size		TA M6	TA M8	TA M10	TA M12
Tension load in uncracked concrete	[kN]	3,0	4,8	7,9	9,9
Displacements	$\frac{\delta_{N0}}{\delta_{N\infty}}$ [mm]	0,7	0,7	1,2	1,2
		1,0	1,0	1,8	1,8
<b>Table C2.3:</b> Displacements under static and quasi static <b>shear</b> loads					
Anchor size		TA M6	TA M8	TA M10	TA M12
Shear load in uncracked concrete	[kN]	3,3	6,7	11,0	17,0
Displacements	$\frac{\delta_{V0}}{\delta_{V\infty}}$ [mm]	2,1	1,9	3,1	3,3
		3,1	2,8	4,6	4,9
<b>fischer Heavy-duty anchor TA M, TA M S, TA M T</b>					<b>Annex C 2</b>
<b>Performances</b>					
Characteristic <b>shear</b> resistance under static and quasi-static loads Displacements under tension and shear loads					