

Centre Scientifique et
Technique du Bâtiment

84, avenue Jean Jaurès
CHAMPS SUR MARNE
F-77447 Marne-la-Vallée Cedex 2
Tél. : (33) 01 64 68 82 82
Fax : (33) 01 60 05 70 37

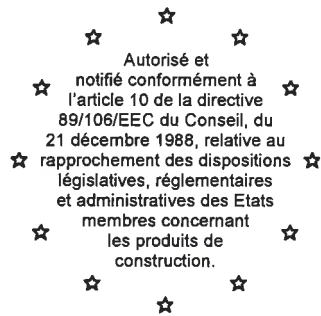

CSTB
le futur en construction

MEMBRE DE L'EOTA

European Technical Approval

ETA-05/0185

(English language translation, the original version is in French language)

Nom commercial :

Trade name:

fischer Anchor bolt EXA

Titulaire :

Holder of approval:

fischerwerke GmbH & Co. KG

Weinhalde 14-18

D-72178 WALDACHTAL

Germany

Type générique et utilisation prévue du
produit de construction :

**Generic type and use of
construction product:**

Cheville métallique électrozinguée, à expansion par vissage à couple
contrôlé, de fixation dans le béton non fissuré : diamètres M8, M10,
M12, M16 et M20.

**Torque-controlled expansion anchor, made of zinc
electroplated steel, for use in non cracked concrete: sizes
M8, M10, M12, M16 and M20.**

Validité du :

au :

Validity from / to:

28/05/2012

03/03/2014

Usine de fabrication :

Manufacturing plant:

fischerwerke,

Le présent Agrément technique européen
contient :

**This European Technical Approval
contains:**

12 pages incluant 5 annexes faisant partie intégrante du document.

**12 pages including 5 annexes which form an integral part of
the document.**

This European Technical Approval replaces ETA-05/0185 with validity from 30/03/2009 to 03/03/2014

Cet Agrément Technique Européen remplace l'Agrément ETA-05/0185 valide du 30/03/2009 au 03/03/2014



Organisation pour l'Agrément Technique Européen
European Organisation for Technical Approvals

I LEGAL BASES AND GENERAL CONDITIONS

1. This European Technical Approval is issued by the Centre Scientifique et Technique du Bâtiment in accordance with:
 - Council Directive 89/106/EEC of 21 December 1988 on the approximation of laws, regulations and administrative provisions of Member States relating to construction products¹, modified by the Council Directive 93/68/EEC of 22 July 1993²; and Regulation (EC) N° 1882/2003 of the European Parliament and of the Council³;
 - Décret n° 92-647 du 8 juillet 1992⁴ concernant l'aptitude à l'usage des produits de construction;
 - Common Procedural Rules for Requesting, Preparing and the Granting of European Technical Approvals set out in the Annex of Commission Decision 94/23/EC⁵;
 - Guideline for European Technical Approval of « Metal Anchors for use in Concrete » ETAG 001, edition 1997, Part 1 « Anchors in general » and Part 3 « Undercut anchors ».
2. The Centre Scientifique et Technique du Bâtiment is authorised to check whether the provisions of this European Technical Approval are met. Checking may take place in the manufacturing plant (for example concerning the fulfilment of assumptions made in this European Technical Approval with regard to manufacturing). Nevertheless, the responsibility for the conformity of the products with the European Technical Approval and for their fitness for the intended use remains with the holder of the European Technical Approval.
3. This European Technical Approval is not to be transferred to manufacturers or agents of manufacturer other than those indicated on page 1; or manufacturing plants other than those indicated on page 1 of this European Technical Approval.
4. This European Technical Approval may be withdrawn by the Centre Scientifique et Technique du Bâtiment pursuant to Article 5 (1) of the Council Directive 89/106/EEC.
5. Reproduction of this European Technical Approval including transmission by electronic means shall be in full. However, partial reproduction can be made with the written consent of the Centre Scientifique et Technique du Bâtiment. In this case partial reproduction has to be designated as such. Texts and drawings of advertising brochures shall not contradict or misuse the European Technical Approval.
6. The European Technical Approval is issued by the approval body in its official language. This version corresponds to the version circulated within EOTA. Translations into other languages have to be designated as such.

¹ Official Journal of the European Communities n° L 40, 11.2.1989, p. 12

² Official Journal of the European Communities n° L 220, 30.8.1993, p. 1

³ Official Journal of the European Union L 284, 31 October 2003, p. 25

⁴ Journal officiel de la République française du 14 juillet 1992

⁵ Official Journal of the European Communities n° L 17, 20.1.1994, p. 34

II SPECIFIC CONDITIONS OF THE EUROPEAN TECHNICAL APPROVAL

1 Definition of product and intended use

1.1. Definition of product

The fischer Anchor bolt EXA in the range of M8 to M20 is an anchor made of zinc electroplated steel, with two expansion sleeves, which is placed into a drilled hole and anchored by torque-controlled expansion.

For the installed anchor see Figure given in Annex 1.

1.2. Intended use

The anchor is intended to be used for anchorages for which requirements for mechanical resistance and stability and safety in use in the sense of the Essential Requirements 1 and 4 of Council Directive 89/106/EEC shall be fulfilled and failure of anchorages made with these products would compromise the stability of the works, cause risk to human life and/or lead to considerable economic consequences. The anchor is to be used only for anchorages subject to static or quasi-static loading in reinforced or unreinforced normal weight concrete of strength classes C 20/25 minimum to C50/60 maximum according to EN 206: 2000-12. It may be anchored in non-cracked concrete only.

The anchor may only be used in concrete subject to dry internal conditions.

The provisions made in this European Technical Approval are based on an assumed intended working life of the anchor of 50 years. The indications given on the working life cannot be interpreted as a guarantee given by the producer, but are to be regarded only as a means for choosing the right products in relation to the expected economically reasonable working life of the works.

2 Characteristics of product and methods of verification

2.1. Characteristics of product

The anchor in the range of M8 to M20 corresponds to the drawings and provisions given in Annexes 1 to 3. The characteristic material values, dimensions and tolerances of the anchor not indicated in Annexes 2 and 3 shall correspond to the respective values laid down in the technical documentation⁶ of this European Technical Approval. The characteristic anchor values for the design of anchorages are given in Annexes 3 to 5.

Each anchor is marked with the identifying mark of the producer, the commercial name, the nominal diameter of the thread and the maximum thickness of the fixture according to Annex 1.

The anchor shall only be packaged and supplied as a complete unit.

2.2. Methods of verification

The assessment of fitness of the anchor for the intended use in relation to the requirements for mechanical resistance and stability and safety in use in the sense of the Essential Requirements 1 and 4 has been made in accordance with the « Guideline for European Technical Approval of Metal Anchors for use in Concrete », Part 1 « Anchors in general » and Part 2 « Torque-controlled expansion anchors », on the basis of Option 7.

⁶ The technical documentation of this European Technical Approval is deposited at the Centre Scientifique et Technique du Bâtiment and, as far as relevant for the tasks of the approved bodies involved in the attestation of conformity procedure, is handed over to the approved bodies.

3 Evaluation of Conformity and CE marking

3.1. Attestation of conformity system

The system of attestation of conformity 2 (i) (referred to as system 1) according to Council Directive 89/106/EEC Annex III laid down by the European Commission provides:

a) tasks for the manufacturer:

1. factory production control,
2. further testing of samples taken at the factory by the manufacturer in accordance with a prescribed test plan.

b) tasks for the approved body:

3. initial type-testing of the product,
4. initial inspection of factory and of factory production control,
5. continuous surveillance, assessment and approval of factory production control.

3.2. Responsibilities

3.2.1. Tasks of the manufacturer, factory production control

The manufacturer has a factory production control system in the plant and exercises permanent internal control of production. All the elements, requirements and provisions adopted by the manufacturer are documented in a systematic manner in the form of written policies and procedures. This production control system ensures that the product is in conformity with the European Technical Approval.

The manufacturer shall only use raw materials supplied with the relevant inspection documents as laid down in the prescribed test plan ⁷. The incoming raw materials shall be subject to controls and tests by the manufacturer before acceptance. Check of incoming materials such as nuts, washers, wire for bolts and sleeves shall include control of the inspection documents presented by suppliers (comparison with nominal values) by verifying dimension and determining material properties, e.g. tensile strength, hardness, surface finish.

The manufactured components of the anchor shall be subjected to the following tests:

- Dimensions of component parts:
 - bolt (diameters, lengths, thread and marking, geometry of the cones);
 - sleeves (length, thickness, catch sizes and marking);
 - hexagonal nut (proper running, wrench size across flats);
 - washer (diameters, thickness).
- Material properties:
 - bolt (yielding and ultimate tensile strengths, hardness),
 - sleeve (yielding and ultimate tensile strengths, hardness),
 - hexagonal nut (proof load),
 - washer (hardness).
- Thickness of the zinc electroplated treatment of the elements.
- Visual control of correct assembly and of completeness of the anchor.

The frequency of controls and tests conducted during production and on the assembled anchor is laid down in the prescribed test plan taking account of the automated manufacturing process of the anchor.

The results of factory production control are recorded and evaluated. The records include at least the following information:

- designation of the product, basic material and components;
- type of control or testing;

⁷

The prescribed test plan has been deposited at the Centre Scientifique et Technique du Bâtiment and is only made available to the approved bodies involved in the conformity attestation procedure.

- date of manufacture of the product and date of testing of the product or basic material and components;
- result of control and testing and, if appropriate, comparison with requirements;
- signature of person responsible for factory production control.

The records shall be presented to the inspection body during the continuous surveillance. On request, they shall be presented to the Centre Scientifique et Technique du Bâtiment.

Details of the extent, nature and frequency of testing and controls to be performed within the factory production control shall correspond to the prescribed test plan which is part of the technical documentation of this European Technical Approval.

3.2.2. Tasks of approved bodies

3.2.2.1. Initial type-testing of the product

For initial type-testing the results of the tests performed as part of the assessment for the European Technical Approval shall be used unless there are changes in the production line or plant. In such cases the necessary initial type-testing has to be agreed between the Centre Scientifique et Technique du Bâtiment and the approved bodies involved.

3.2.2.2. Initial inspection of factory and of factory production control

The approved body shall ascertain that, in accordance with the prescribed test plan, the factory and the factory production control are suitable to ensure continuous and orderly manufacturing of the anchor according to the specifications mentioned in 2.1. as well as to the Annexes to the European Technical Approval.

3.2.2.3. Continuous surveillance

The approved body shall visit the factory at least once a year for regular inspection. It has to be verified that the system of factory production control and the specified automated manufacturing process are maintained taking account of the prescribed test plan.

Continuous surveillance and assessment of factory production control have to be performed according to the prescribed test plan.

The results of product certification and continuous surveillance shall be made available on demand by the certification body or inspection body, respectively, to the Centre Scientifique et Technique du Bâtiment. In cases where the provisions of the European Technical Approval and the prescribed test plan are no longer fulfilled the conformity certificate shall be withdrawn.

3.3. CE-Marking

The CE marking shall be affixed on each packaging of anchors. The symbol « CE » shall be accompanied by the following information:

- identification number of the certification body;
- name or identifying mark of the producer and manufacturing plant;
- the last two digits of the year in which the CE-marking was affixed;
- number of the EC certificate of conformity;
- number of the European Technical Approval;
- use category (ETAG 001-1 Option7);
- size.

4 Assumptions under which the fitness of the product for the intended use was favourably assessed

4.1. Manufacturing

The anchor is manufactured in accordance with the provisions of the European Technical Approval using the automated manufacturing process as identified during inspection of the plant by the Centre Scientifique et Technique du Bâtiment and the approved body and laid down in the technical documentation.

4.2. Installation

4.2.1. Design of anchorages

The fitness of the anchors for the intended use is given under the following conditions:

- The anchorages are designed in accordance with the « Guideline for European Technical Approval of Metal Anchors for Use in Concrete », Annex C, Method A, for torque-controlled expansion anchors under the responsibility of an engineer experienced in anchorages and concrete work.
- Verifiable calculation notes and drawings are prepared taking account of the loads to be anchored.
- The position of the anchor is indicated on the design drawings (e.g. position of the anchor relative to reinforcement or to support, etc.).

4.2.2. Installation of anchors

The fitness for use of the anchor can only be assumed if the anchor is installed as follows:

- anchor installation carried out by appropriately qualified personnel and under the supervision of the person responsible for technical matters on the site;
- use of the anchor only as supplied by the manufacturer without exchanging the components of an anchor;
- anchor installation in accordance with the manufacturer's specifications and drawings prepared for that purpose and using the appropriate tools;
- thickness of the fixture corresponding to the range of required thickness values for the type of anchor;
- checks before placing the anchor to ensure that the strength class of the concrete in which the anchor is to be placed is in the range given and is not lower than that of the concrete to which the characteristic loads apply;
- check of concrete being well compacted, e.g. without significant voids;
- clearing the hole of drilling dust;
- anchor installation ensuring the specified embedment depth: embedment depth control (with the exception of the shorter length of each anchor size, the fixture shall be removed to check the anchor length);
- keeping of the edge distance and spacing to the specified values without minus tolerances;
- positioning of the drill holes without damaging the reinforcement;
- in case of aborted hole: new drilling at a minimum distance away of twice the depth of the aborted hole or smaller distance if the aborted drill hole is filled with high strength mortar and if under shear or oblique tension load it is not to the anchor in the direction of load application;
- application of the torque moment given in Annex 3 using a calibrated torque wrench.

4.2.3. Responsibility of the manufacturer

It is the manufacturer's responsibility to ensure that the information on the specific conditions according to 1 and 2 including Annexes referred to in 4.2.1. and 4.2.2. is given to those who are concerned. This information may be made by reproduction of the respective parts of the European Technical Approval. In addition all installation data shall be shown clearly on the package and/or on an enclosed instruction sheet, preferably using illustration(s).

The minimum data required are:

- drill bit diameter,
- thread diameter,
- maximum thickness of the fixture,
- minimum installation depth,
- minimum hole depth,
- required torque moment,
- information on the installation procedure, including cleaning of the hole, preferably by means of an illustration,
- reference to any special installation equipment needed,
- identification of the manufacturing batch.

All data shall be presented in a clear and explicit form.

The original French version is signed by

**Le Directeur Technique
C. BALOCHE**

M8, M10 and M12: Cone bolt manufactured by cold - forming:

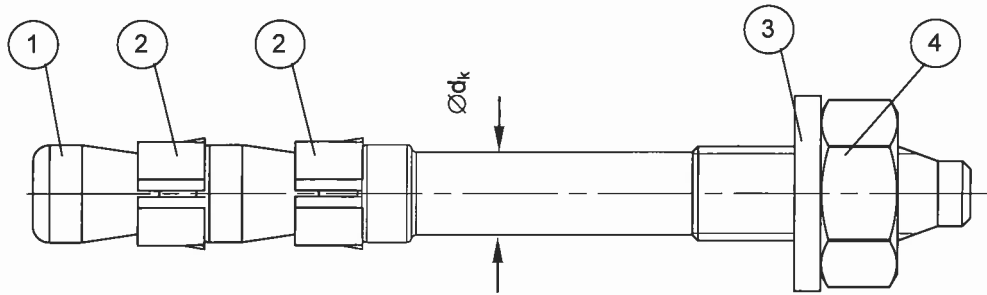

M12, M16 and M20: Cone bolt manufactured by metal - cutting:

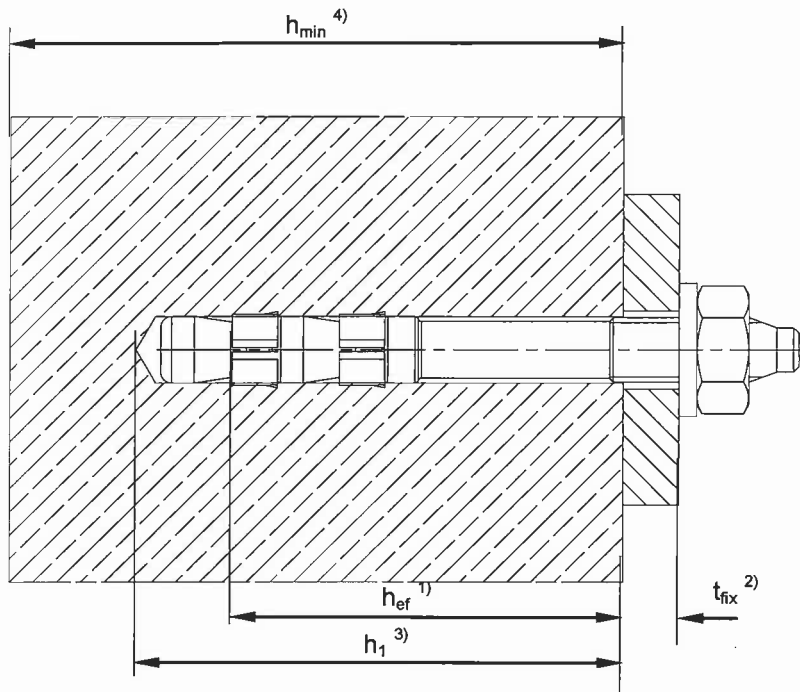
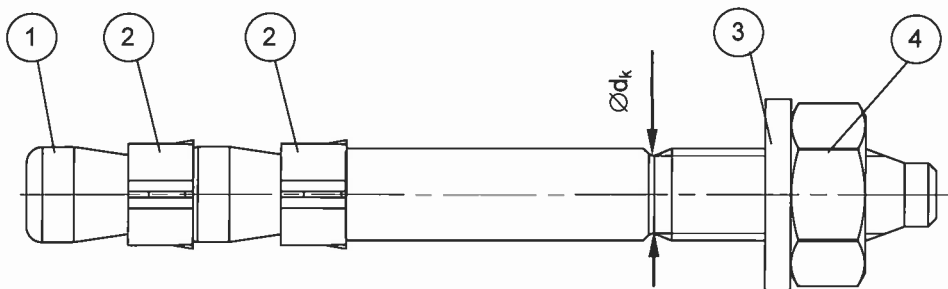

- ① Cone bolt (cold – formed or metal - cut)
- ② Expansion sleeve
- ③ Washer
- ④ Hexagon nut

- 1) effective anchorage depth
- 2) thickness of fixture
- 3) drill hole depth
- 4) min. thickness of concrete member

<p>fischer Anchor bolt EXA</p>	<p>Annex 1</p>
<p>Product and intended use</p>	<p>of European Technical Approval ETA – 05/0185</p>

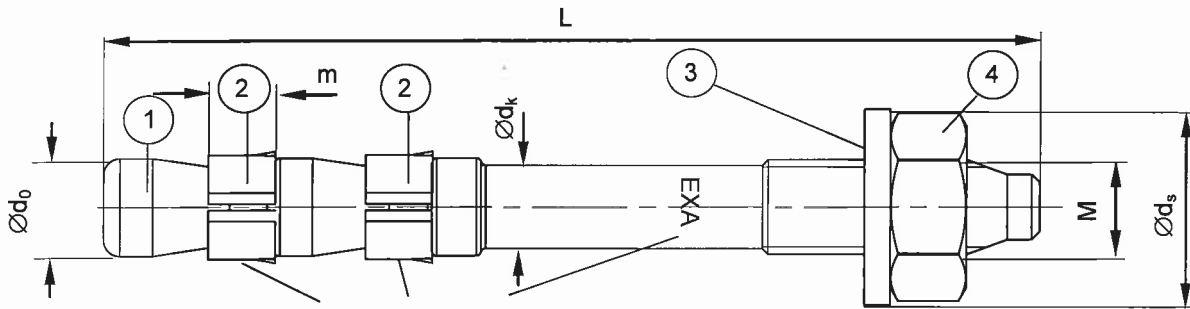

Marking Cone Bolt on lateral surface and/or on sleeves
 U EXA 8 /28

maximal thickness of fixture ($t_{fix, max}$)
thread size
type of anchor
works symbol

Table 1: Anchor dimensions [mm]

Part	Designation	Dimensions	EXA M8	EXA M10	EXA M12	EXA M16	EXA M20
1	Cone bolt	M	8	10	12	16	20
		$\varnothing d_0$	= 7,9	= 9,9	= 11,9	= 16,0	= 20,0
		$\varnothing d_k$	= 7,1	= 8,9	= 10,8	= 15,5	= 18,2
2	Expansion	m	= 5,3	= 6,4	= 7,2	= 10,3	= 12
3	Washer	t_s	\geq 1,4	\geq 1,8	\geq 2,3	\geq 2,7	\geq 2,7
		$\varnothing d_s$	\geq 15	\geq 19	\geq 23	\geq 29	\geq 36
4	Hexagon nut	SW	13	17	19	24	30
	Thickness of fixture t_{fix}	min	\geq 0	\geq 0	\geq 0	\geq 0	\geq 0
		max	\leq 200	\leq 250	\leq 350	\leq 400	\leq 500
	Length of anchor	L_{min}	68	73	97	122	146
		L_{max}	267	323	446	522	646

Table 2: Materials

Part	Designation	Material	Treatment
1	Cone bolt	Cold form steel or free cutting steel	Zinc plated $\geq 5 \mu m$ according to EN ISO 4042
2	Expansion sleeve	Cold strip, EN 10088-2 or EN 10139	EN 10088-2: --- EN 10139: Zinc plated $\geq 5 \mu m$ according to EN ISO 4042
3	Washer	Cold strip, EN 10139	Zinc plated $\geq 5 \mu m$ according to EN ISO 4042;
4	Hexagon nut	Steel, property class 8, EN 20898-2	Nuts M8 and M10 with coating

fischer Anchor bolt EXA

Anchor dimensions and materials

Annex 2

of European
 Technical Approval
ETA - 05/0185

Table 3: Installation parameters

Type of anchor / size		EXA M8	EXA M10	EXA M12	EXA M16	EXA M20
Nominal drill hole diameter	$d_0 =$ [mm]	8	10	12	16	20
Cutting diameter of drill bit	$d_{cut} \leq$ [mm]	8,45	10,45	12,5	16,5	20,55
Effective anchorage depth	$h_{ef} \geq$ [mm]	47	49	67	85	103
Depth of drill hole in concrete	$h_1 \geq$ [mm]	60	65	85	110	130
Minimum thickness of concrete member	$h_{min} \geq$ [mm]	100	100	135	170	205
Diameter of clearance hole in the fixture	$d_f \leq$ [mm]	9	12	14	18	22
Required torque moment	$T_{inst} =$ [Nm]	14	30	60	80	140

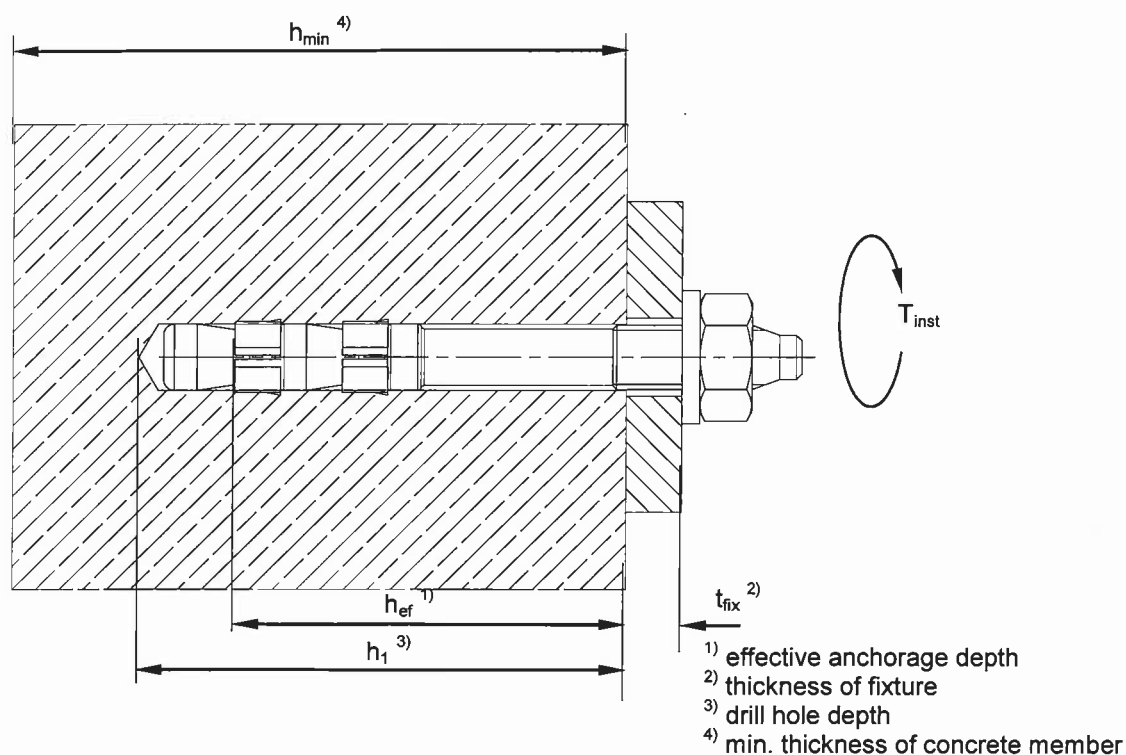

Table 4: Minimum spacing and minimum edge distances of anchors

Type of anchor / size		EXA M8	EXA M10	EXA M12	EXA M16	EXA M20
Minimum spacing	s_{min} [mm]	45	50	75	85	105
	for $c \geq$ [mm]	60	85	90	145	170
Minimum edge distance	c_{min} [mm]	40	65	90	90	100
	for $s \geq$ [mm]	100	100	75	145	170

fischer Anchor bolt EXA

Parameters of installation

Annex 3
 of European
 Technical Approval
ETA - 05/0185

Table 5: Design method A - characteristic values for tension loads

Type of anchor / size			EXA M 8	EXA M 10	EXA M 12	EXA M 16	EXA M 20
Steel failure							
Characteristic resistance	$N_{Rk,s}$	[kN]	23	35	48	62	108
Partial safety factor	γ_{Ms} ¹⁾	-	1,48	1,44	1,40	1,57	1,57
Pullout							
Characteristic resistance in non-cracked concrete C20/25	$N_{Rk,p}$	[kN]	12	16	25	35	52
Partial safety factor	γ_2	-	1,4	1,2	1,2	1,0	1,0
	γ_{Mp} ²⁾	-	2,1	1,8	1,8	1,5	1,5
Increasing factors for $N_{Rk,p}$	ψ_c	C25/30	1,10				
		C30/37	1,22				
		C35/45	1,34				
		C40/50	1,41				
		C45/55	1,48				
		C50/60	1,55				
Concrete cone and splitting failure							
Effective anchorage depth	h_{ef}	[mm]	47	49	67	85	103
Spacing	$s_{cr,N}$	[mm]	140	150	200	260	310
Edge distance	$c_{cr,N}$	[mm]	70	75	100	130	155
Spacing (splitting failure)	$s_{cr,sp}$	[mm]	330	340	425	425	515
Edge distance (splitting failure)	$c_{cr,sp}$	[mm]	165	170	215	215	260
Partial safety factor	γ_2	-	1,4	1,2	1,2	1,0	1,0
	γ_{Mc} ¹⁾	-	2,1	1,8	1,8	1,5	1,5

¹⁾ In absence of other national regulations.

²⁾ Includes γ_2

Table 6: Displacements due to tension loads

Type of anchor / size			EXA M 8	EXA M 10	EXA M 12	EXA M 16	EXA M 20
Tension load in C20/25 to C50/60	N	[kN]	3,4	5,3	8,3	13,9	20,6
Displacements	δ_{N0}	[mm]	0,1	0,1	0,1	0,2	0,3
	$\delta_{N\infty}$	[mm]	0,3	0,3	0,3	0,3	0,6

fischer Anchor bolt EXA

**Design method A,
 characteristic values for tension loads, displacements**

Annex 4

of European
 Technical Approval
ETA - 05/0185

Table 7: Design method A - characteristic values for shear loads

Type of anchor / size			EXA M 8	EXA M 10	EXA M 12	EXA M 16	EXA M 20
Steel failure without lever arm							
Characteristic resistance	$V_{Rk,s}$	[kN]	13	19	23 ²⁾	51 ²⁾	75 ²⁾
Partial safety factor	γ_{Ms} ¹⁾	-	1,50	1,50	1,50	1,31	1,31
Steel failure with lever arm							
Characteristic bending moment	$M_{Rk,s}^0$	[Nm]	27	50	85	183	357
Partial safety factor	γ_{Ms} ¹⁾	-	1,50	1,50	1,50	1,31	1,31
Concrete pryout failure							
Factor in equation (5.6) of the guideline Annex C, Section 5.2.3.3	k	-	1	1	2	2	2
Partial safety factor	γ_{Mc} ¹⁾	-	1,5 ³⁾				
Concrete edge failure							
Effective length of anchor	l_f	[mm]	47	49	67	85	103
Effective external diameter of anchor	d_{nom}	[mm]	8	10	12	16	20
Partial safety factor	γ_{Mc} ¹⁾	-	1,5 ³⁾				

Table 8: Displacements due to shear loads

Type of anchor / size			EXA M 8	EXA M 10	EXA M 12	EXA M 16	EXA M 20
Shear load C20/25 to C50/60	V	[kN]	6,2	9,1	11,0	27,8	40,9
Displacements	δ_{V0}	[mm]	2,7 ⁴⁾	4,5 ⁴⁾	2,5 ⁴⁾	3,2 ⁴⁾	5,5 ⁴⁾
	$\delta_{V\infty}$	[mm]	3,8 ⁴⁾	6,1 ⁴⁾	3,1 ³⁾	4,3 ⁴⁾	7,6 ⁴⁾

¹⁾ In absence of other national regulations.

²⁾ Values issued from the test series because the failure does not occur in the threaded part.

³⁾ The partial safety factor $\gamma_2 = 1,0$ is included

⁴⁾ All values including axial clearance from anchor and attachment part.

Installation instructions

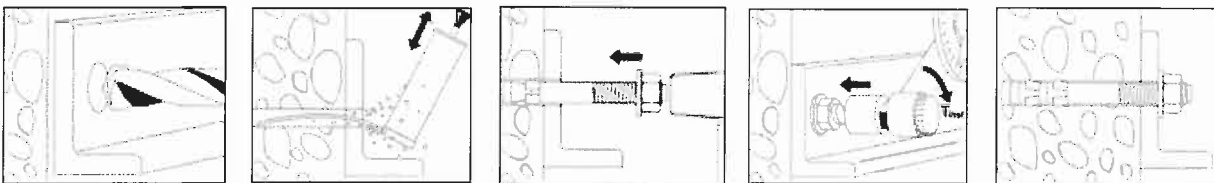

Fischer Anchor bolt EXA

**Design method A,
 characteristic values for shear loads, displacements
 Installation instructions**

Annex 5

of European
 Technical Approval
ETA - 05/0185